

The logo consists of a dark blue rectangular box containing the text 'CNC-TECHNIEK' in a light blue, sans-serif font, and 'DECALF.' in a larger, white, bold, sans-serif font below it. The background of the entire page features a close-up of several precision-machined metal gears and components, with a futuristic overlay of glowing blue and red light trails and circuit patterns.

**CNC-TECHNIEK
DECALF.**

CNC draai- en freeswerk



CNC draai- & freeswerk

Precisie, snelheid en flexibiliteit in CNC draai- en freeswerk

Op zoek naar hoogwaardige CNC draai- en freesbewerkingen met maximale betrouwbaarheid én korte levertijden? Wij bieden u niet alleen vakmanschap tot op de micron nauwkeurig, maar ook onze exclusieve Fast Lane Service voor spoedopdrachten.

Daarmee profiteert u van razendsnelle doorlooptijden zonder concessies aan kwaliteit. Ideaal voor urgente projecten, prototypen of just-in-time productie. Laat uw onderdelen bij ons draaien en frezen – snel, precies en volgens afspraak.

CNC draai- & freeswerk

CNC draaibank QTE-300MY SMOOTH

- Max. verspaningslengte 1054,5 mm
- Zwaaidiameter 728mm
- Max. draaidiameter 340mm
- Y-as (Bewerkingen uit het center)
- Max. stafdiameter (doorlaat) 80mm
- Max. gewicht aswerkstuk 500kg
- Motor vermogen 18,5kW
- Revolverkop met 12 gereedschapsposities, voorzien van enkele aangedreven gereedschappen



REALISATIES

CNC draaibank
QTE-300MY SMOOTHIEZ

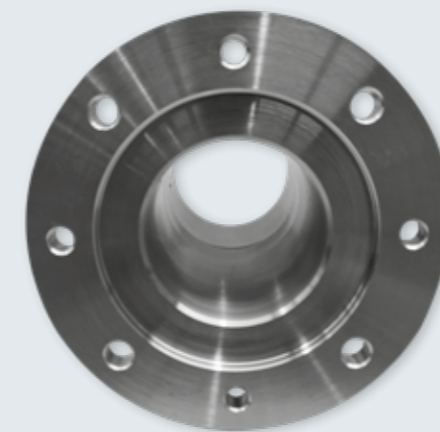
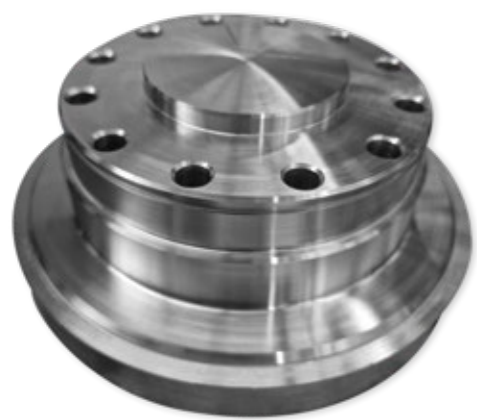
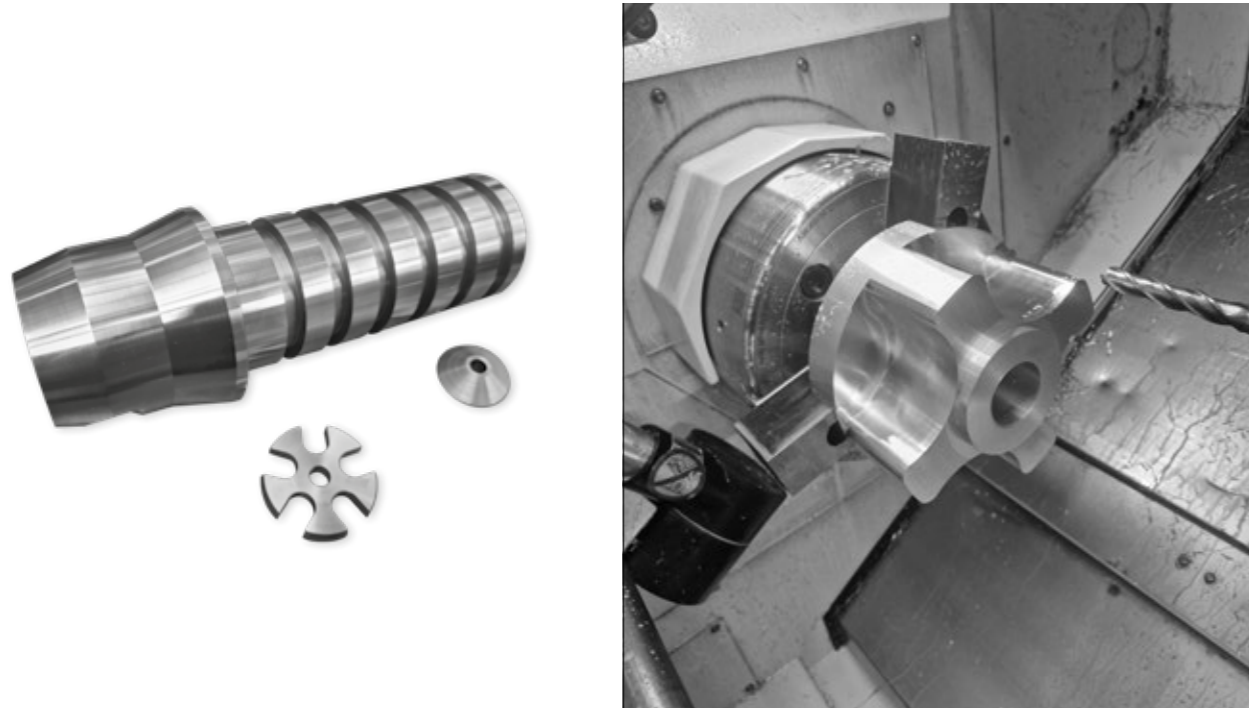

CNC draai- & freeswerk

CNC freesmachine VCN-600 SMOOTH G

- 3-assig
- Asverplaatsingen (X,Y,Z): 1.050mm, 600mm, 600mm
- Max. Capaciteit (l x b x h) 1.300 x 600 x 650mm
- Max. werkstukgewicht 1200kg
- 30kW spindelmotor
- 18.000 tr/min (hoge snelheidsspindel)
- Gereedschapsmagazijn 60 posities
- Hogedruk koelwaterpomp 70 bar
- Renishaw meettaster nauwkeurigheid 0.0001mm

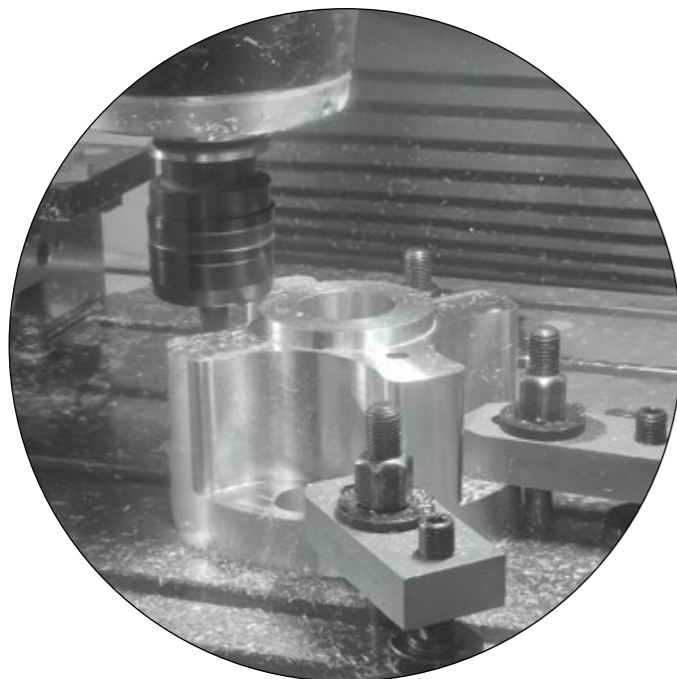

REALISATIES

CNC freesmachine
VCN-600 SMOOTH G

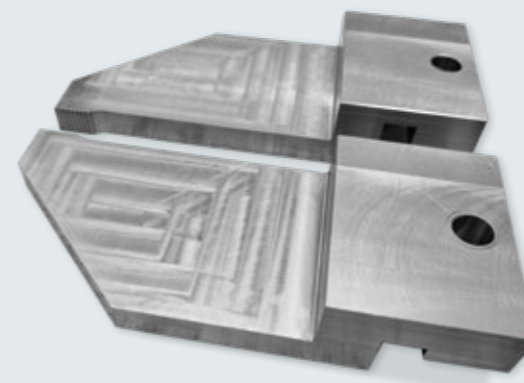
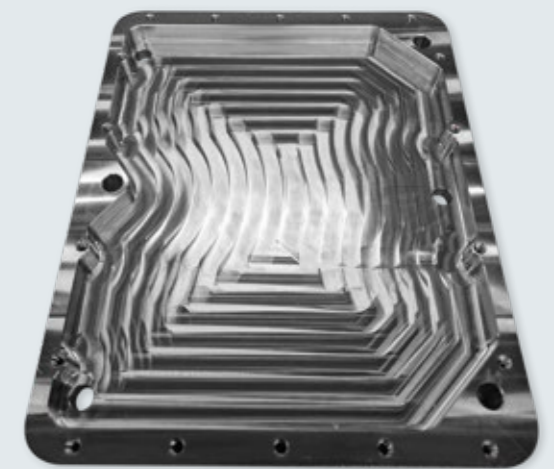



CNC - TECHNIEK DECALF

Wissenstraat 13
9200 Dendermonde
T. +32 (0)52 411 999

cnc@electro-decalf.be
www.electro-decalf.be

